

HVR170H-11 NVR170H-11 (HVA170-11)

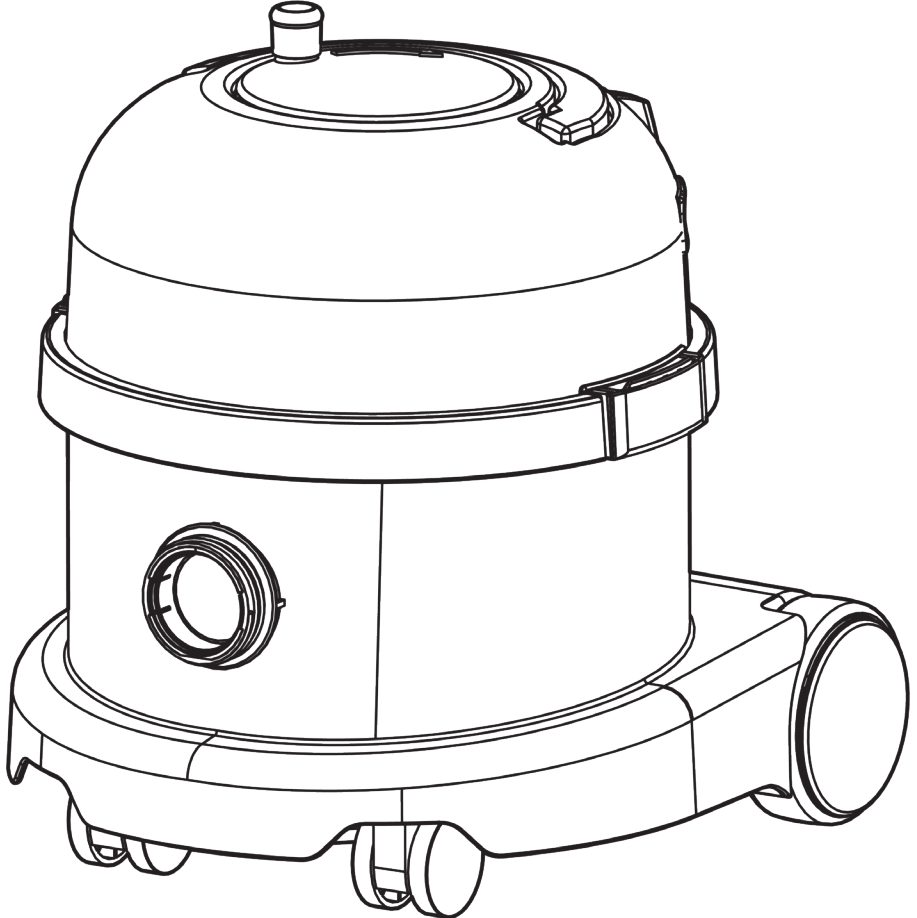

Kit AS32 / AS0 / AS0 (270) / AS2 (c/w 909918) (Australian)



Edgar Edmondson Pty Ltd

Head Office Delivery and Shipping Address
PO Box 198 18 Garden St
Marrickville Marrickville
NSW 1475 NSW 2204
AUSTRALIA AUSTRALIA

Office Number: 1800 BUY MOP
Fax Number: +61 (0)2 9519 9223
E-Mail: orders@edmondson.net.au
ABN: 27 000 450 144

Edco

Original Instructions -
CAUTION, Read instructions before using the machine.

Kit AS32 / AS0 / AS0 (270) / AS2 (c/w 909918)

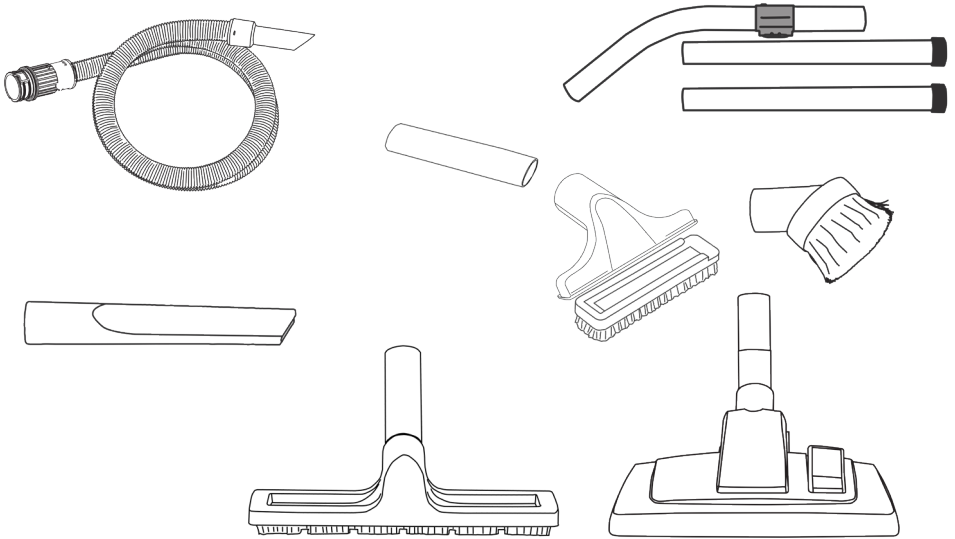

Assembly

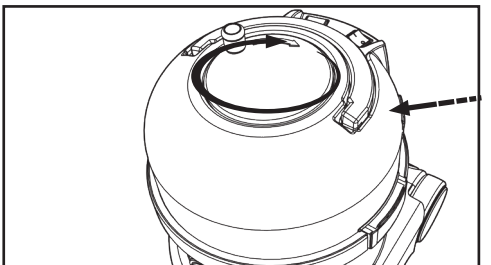
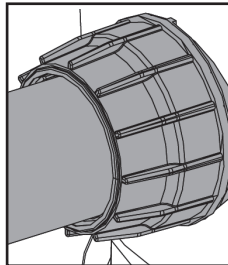
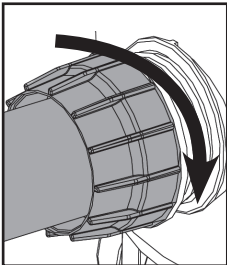
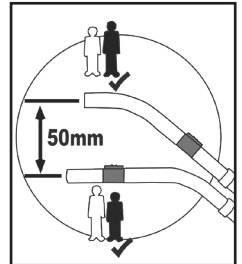
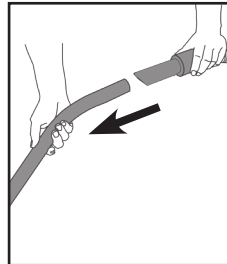
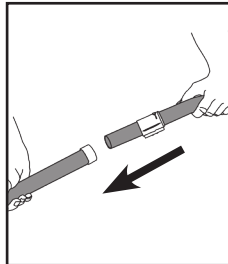
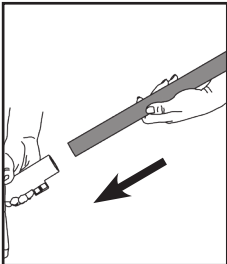

Using your machine

Start

Power On Indicator Light

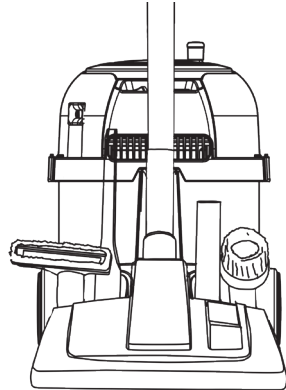
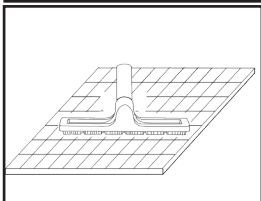
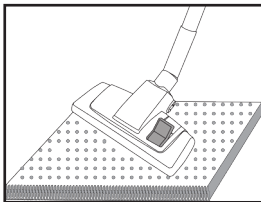
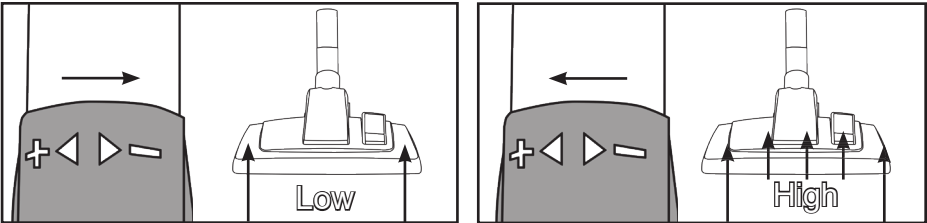
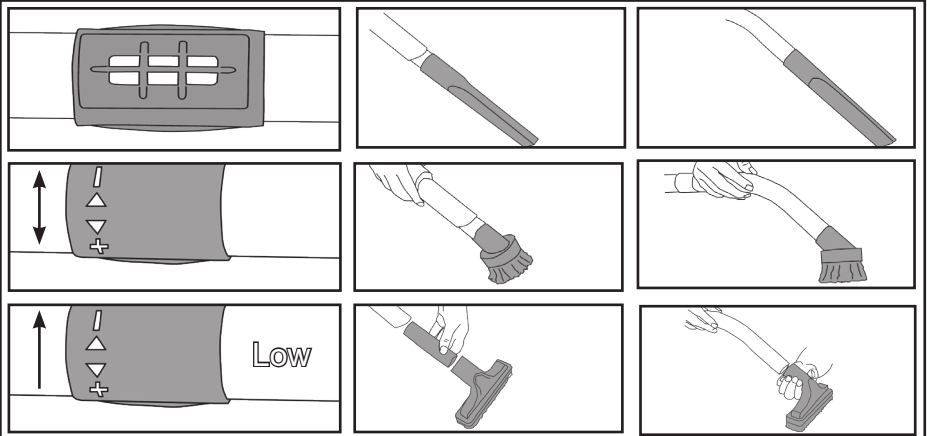
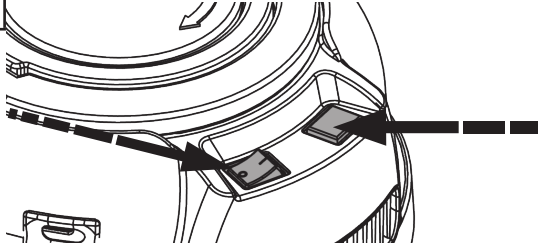

Cleaning

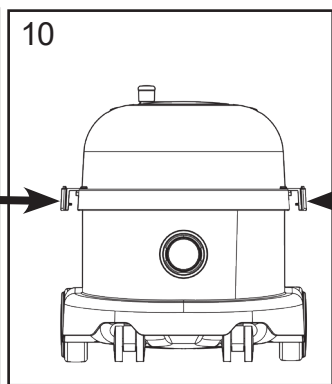
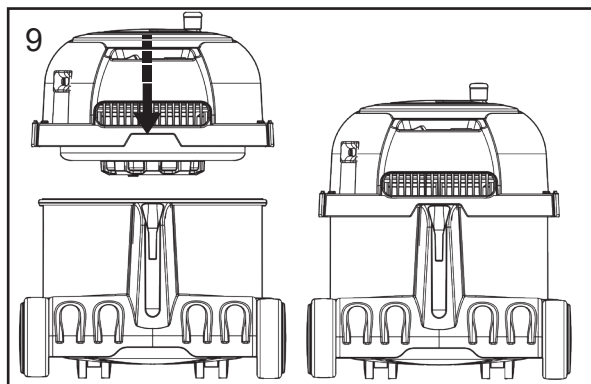
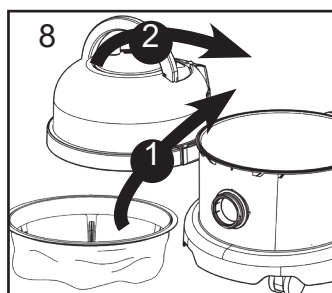
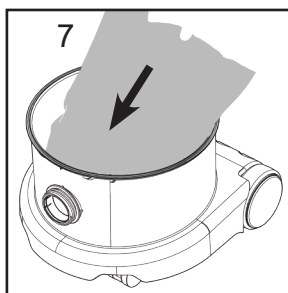
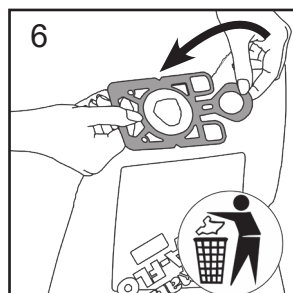
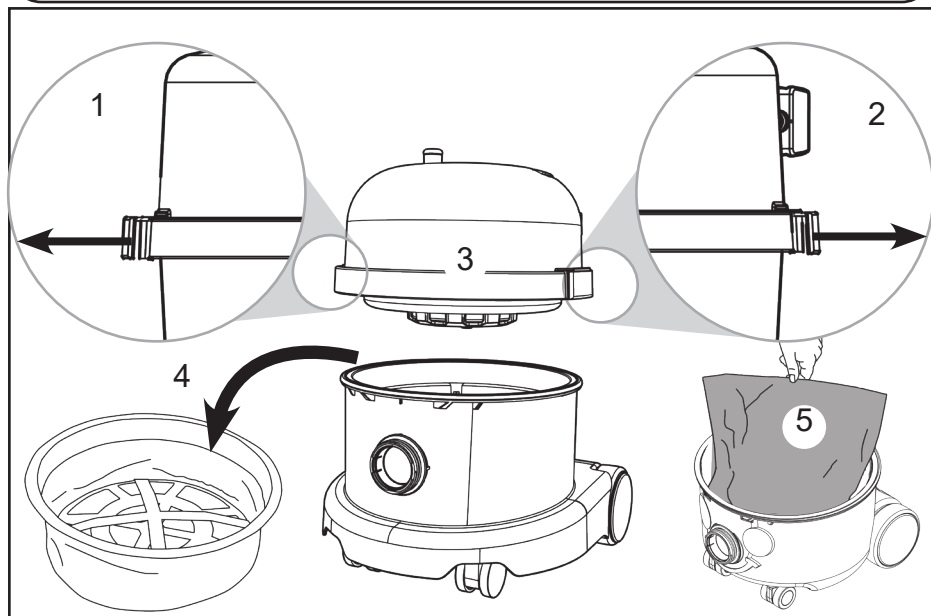

Replacing the Cartridge Filter

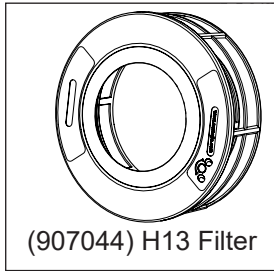
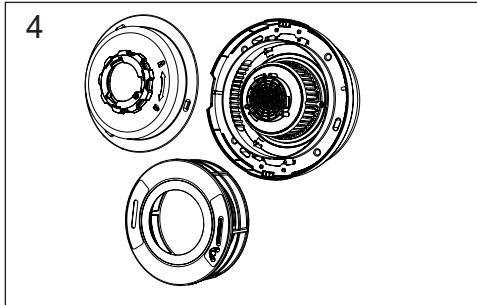
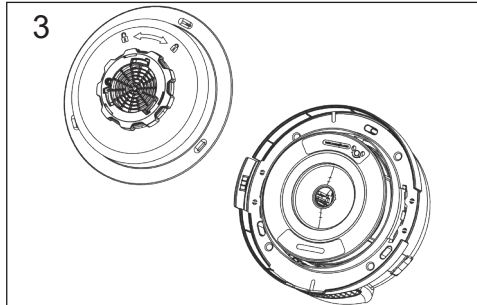
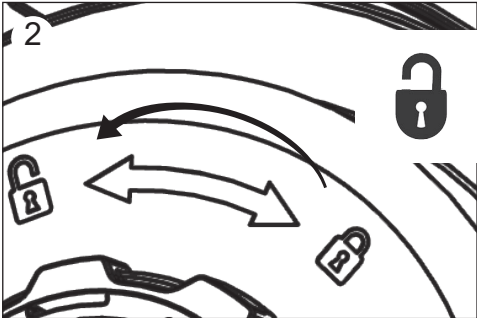
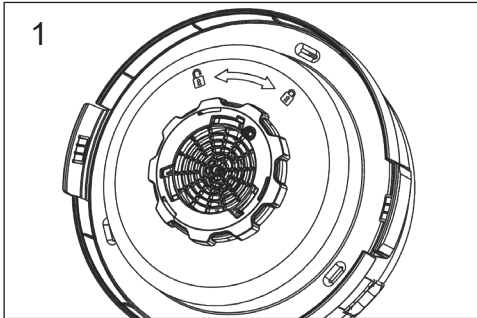

Tool tidy

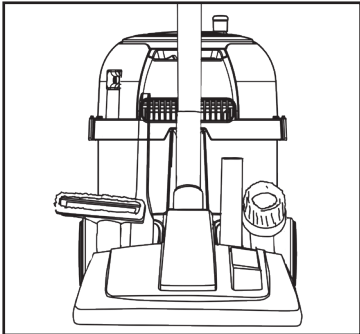
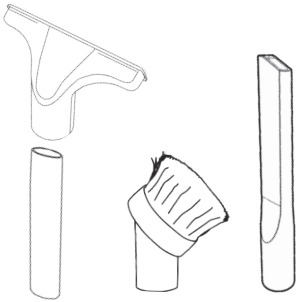
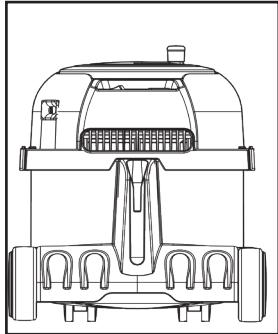

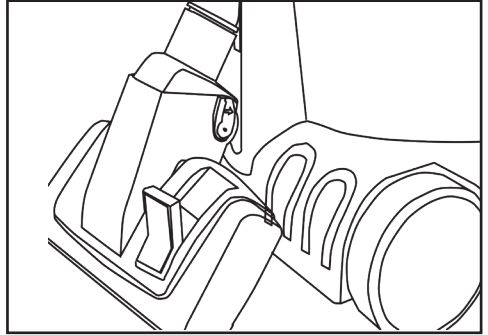
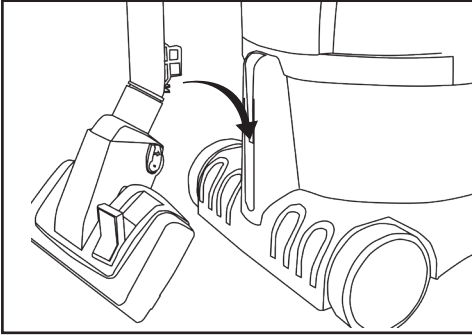

Notes

A series of horizontal dotted lines for taking notes.

Schematic Diagram

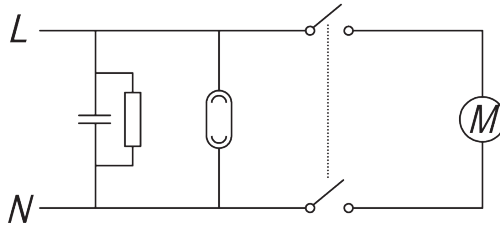

Replacement parts

TriTex Filter	
909560	TriTex Filter
Motor Filter	
907044	H13 Post Motor Filter
HepaFlo Dust Bags	
909291	NVH 1CH (Pack of 3)
907076	NVH 1CH (Pack of 5)
907075	NVH 1CH (Pack of 10)

Data

	1	2	3	4	5	6
170	7.2 L	26.4 m	8.2 kg	LpA ≤ 70 dB (A)	Class II	360 mm x 370 mm x 390 mm

1	2	3	4	5	6
Drum Size	Cleaning Range	Weight (Ready to work)	Sound Pressure	Protection Class	Dimensions

Rating Label

1	Company Name & Address
2	Model
3	Voltage / Alternating Current
4	Frequency
5	Rated Input Power
6	Weight
7	Protection Class 2 Symbol
8	Approval Mark
9	Machine yr/wk Serial Number

About your machine (GB) 1.3

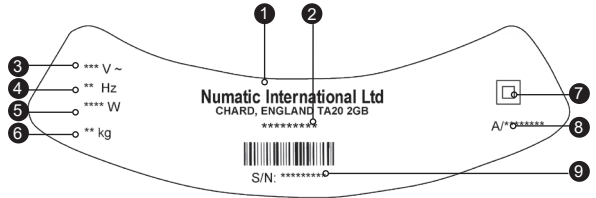

Daily

Keep the machine clean, including hoses and tubes.
Ensure the bag and filter are fitted.
Regularly examine the power cord.
Check dust bag frequently.
Check filters are clean.

Weekly - as daily and:-

Check for any worn or damaged parts and replace immediately.

Maintenance

PPE (personal protective equipment). That may be required for certain operations.

Ear Protection	Safety Footwear	Head Protection	Safety Gloves	
Eye Protection	Protective Clothing	Dust / Allergens Protection	Hi Viz Jacket	Caution Floor Sign

NOTE: A risk assessment should be conducted to determine which PPE should be worn.

Safety Critical Components

Mains leads:

H05-V2V2-F 10m x 2 Core x 1.00 mm²

GTSA-2 10m x 2 Core x 1.00 mm²

WARNING

Read the instruction manual before using the machine.

Operators shall be adequately instructed on the use of their machine.

As with all electrical equipment, care and attention must be exercised at all times during use, in addition to ensuring that routine and preventative maintenance is carried out periodically to ensure safe operation.

Failure to carry out maintenance as necessary, including the replacement of parts to the correct standard could render this equipment unsafe and the manufacturer can accept no responsibility in this respect.

Maintenance should only be carried out by a qualified person.

This machine is for DRY USE only and must not be stored outside or used in wet conditions.

The machine shall be disconnected from the mains power by removing the plug from the power supply socket during cleaning or maintenance and when replacing parts or converting the machine to another function.

Only use the socket outlet on the machine for purposes specified in the instructions (if fitted).

This machine is not to be used by children or persons with reduced physical, sensory or mental capabilities, or lack of experience or knowledge.

This appliance is intended to be cleaned and maintained by an adult.

Children being supervised are not to play with the machine.

This machine is not a toy.

This machine is not suitable for picking up hazardous or explosive dust.

Contact your local distributor if you require a machine capable of performing these tasks.

CAUTION

Ensure that the filtration system fitted to the machine is suitable for the material being collected.

This vacuum cleaner is intended for indoor use in the collection of dry materials.

This machine should be stored indoors only.

NOTES

The primary use for this machine is commercial, for example in hotels, schools, hospitals, factories, shops and offices.

This product complies with the requirements of clause 20 of IEC/EN 60335-2-69 Stability and Mechanical Hazards.

This vacuum cleaner is fitted with a thermal protection device. If the vacuum cleaner stops working, remove the plug from the wall before investigating where the fault lies.

If the vacuum cleaner has a blockage, switch off, remove the plug from the power socket, inspect the floor tool, tubes and hose for debris. If the floor tool, tubes and hose are clear, replace the dust bag and clean the filter.

The vacuum cleaner should be inspected after use for damage.

The vacuum cleaner should be stored in a dry place.

When moving from one place to another, consider the weight of the machine.

DO

- Keep your machine clean including hoses and tubes.
- Change dust bag frequently.
- Keep filters clean.
- Keep diffuser filter (where fitted) clean.
- Use filter bags, they will enhance performance and help keep machine clean.
- Use a Numatic Original filter bag under fine dust conditions.
- Keep hoses and tubes clear.
- Replace any worn or damaged parts immediately.
- Only use the brushes provided with the machine. The use of other brushes may impair safety.
- Regularly examine the power cord. If damage is found such as cracking or ageing the power cord must be replaced by a qualified person.
- Only replace the power cord with the correct Numatic approved replacement part.

DO NOT

- Pull on the cable to unplug the machine from the power supply.
- Use to suck up hot ashes or lighted cigarette ends.
- Use steam cleaners or pressure washers to clean the machine or use in the rain.
- Immerse in water for cleaning.
- Attempt machine maintenance or cleaning unless the power supply plug has been removed from the supply outlet.
- Use in wet environments or to collect wet materials.
- Under any circumstances place foreign objects including (but not limited to) air fresheners, air freshener capsules or scented beads of any type into the top filter of the machine. Doing so can be dangerous and risk damage to the machine and may invalidate the machine warranty.

Notes

.....
.....
.....
.....
.....
.....
.....
.....
.....
.....
.....
.....
.....
.....
.....
.....
.....
.....
.....
.....
.....
.....
.....

We hereby confirm that the filter in this product conforms to H13: 99.95% (EN1822)
The unit as tested conforms to FED STD 209E Class 1000 (M4.5) classification and conforms to
BS EN ISO 14644-1 Class 6 Classification.
Maximum Total Particles equal to or larger than 0.5µm ≤ 35,300 / m³



Warranty

Numatic International Limited warrant to the original purchaser that its products are free of defects in both material and workmanship for the period shown below:-

- Homecare and Procare Vacuum cleaners..... 2 Years**
- Rotary Floor Machines..... 1 Year**
- Twintec Auto Scrubber Dryer..... 1 Year**
- Vario Ride-On Scrubber Dryer..... 1 Year / 1500 hours**
- Mopping, Compacts, Versaclean and Versacare Products..... 1 Year**
- Individual Accessories and Spare Parts..... 6 Months**

Note: This warranty expressly excludes consumable parts such as carbon brushes, floor brushes, mops, batteries etc, that are considered replaceable from time to time during the normal working life of the machine.

Our goods come with guarantees that cannot be excluded under the Australian Consumer Law. You are entitled to a replacement or refund for a major failure and for compensation for any other reasonably foreseeable loss or damage. You are also entitled to have the goods repaired or replaced if the goods fail to be of acceptable quality and the failure does not amount to a major failure.

The benefits under (Our Warranty) are in addition to other rights and remedies under a law in relation to the (goods/services)

- A. The warranty period commences from the date the goods are purchased. We advise all purchasers to retain their invoice as proof of purchase.
- B. All warranty claims must be processed through either the Dealer from whom the equipment was originally purchased or another authorised Edgar Edmondson Pty Ltd Australia dealer. The Dealer will co-operate with the purchaser throughout the warranty claims procedure and will arrange any necessary repairs using genuine Numatic parts.
- C. If the original Dealer is no longer able to fulfil his obligations please contact Edgar Edmondson Pty Ltd Australia with full details of the claim and proof of purchase so that this may be processed without delay.
- D. Any warranty claim can only relate to the specific part that is proven to be at fault and for which a replacement will be supplied but cannot be extended to constitute a claim against the complete machine.
- E. Edgar Edmondson Pty Ltd Australia will supply the Dealer with any warranty parts required, subject to the claim being validated.
- F. Claims will not be accepted if they are the result of fair wear and tear, misuse or abuse of any kind.
- G. No replacement will be given unless the appropriate evidence of the validity of the claim has been provided to the satisfaction of Edgar Edmondson Pty Ltd Australia.
- H. Edgar Edmondson Pty Ltd Australia reserve the right to charge for any work carried out as a result of an invalid claim.
- I. No variation to this warranty may be made or implied by any member of Edgar Edmondson Pty Ltd Australia or its Dealers unless such variation is in writing and authorised by the Company.

Australian Importer.

Edgar Edmondson Pty Ltd

Head Office	Delivery and Shipping Address	Office Number: 1800 BUY MOP
PO Box 198	18 Garden St	Fax Number: +61 (0)2 9519 9223
Marrickville	Marrickville	E-Mail: orders@edmondson.net.au
NSW 1475	NSW 2204	
AUSTRALIA	AUSTRALIA	ABN: 27 000 450 144





Distributed by:-

Australian Importer

Edgar Edmondson Pty Ltd

Head Office
PO Box 198
Marrickville
NSW 1475
AUSTRALIA

Delivery and Shipping Address
18 Garden St
Marrickville
NSW 2204
AUSTRALIA

Office Number: 1800 BUY MOP
Fax Number: +61 (0)2 9519 9223
E-Mail: orders@edmondson.net.au
ABN: 27 000 450 144

Edco



Numatic International Limited.
Chard, Somerset TA20 2GB ENGLAND
Tel: 01460 68600 www.numatic.co.uk

Specification subject to change without prior notice
www.numatic.co.uk © Numatic International Limited

911020 10/21 (A06)